

# SWITCH Musical Fountain Nozzle

Dynamic Water Patterns for Every Setting

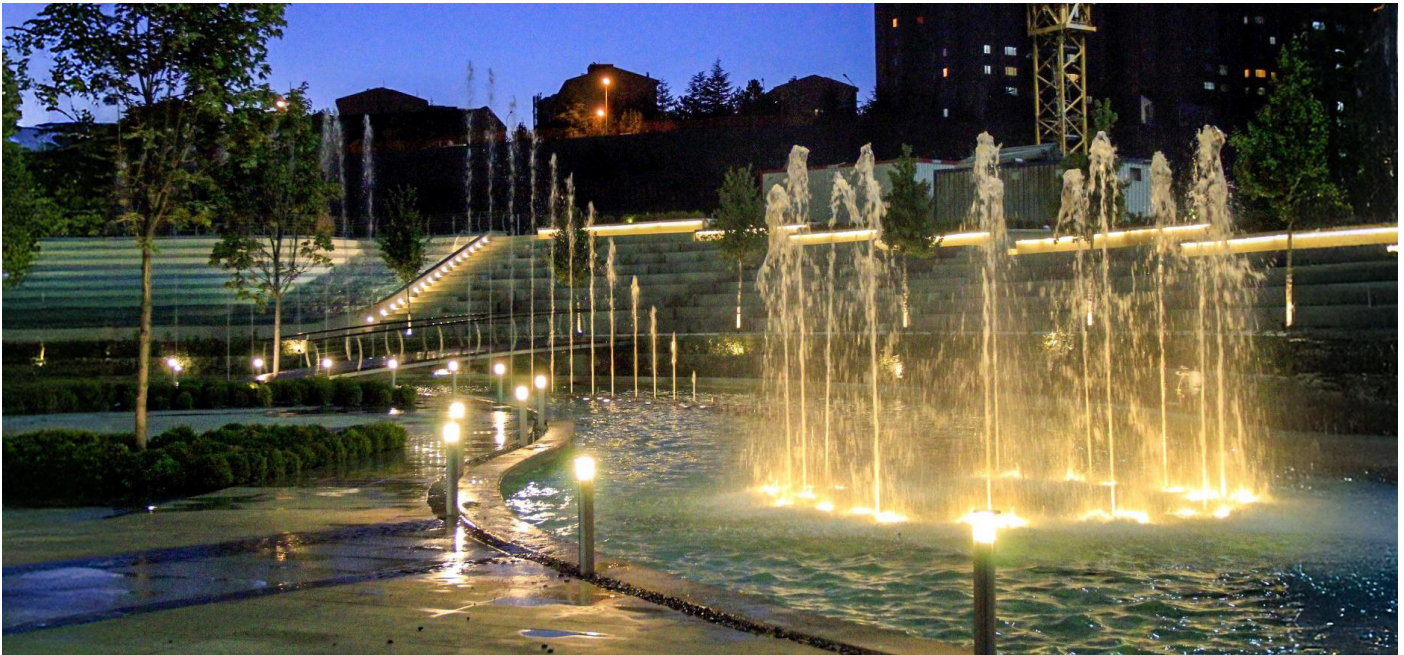

Our Solenoid-Controlled SWITCH nozzle is specifically designed for show fountains system, delivering exceptional performance without pressure loss or water hammer effects. This advanced nozzle enables rapid operation, allowing you to create captivating water displays at a moment's notice. It's the perfect choice for show fountains, especially DryDeck applications, and decorative water features. Enhance your aquatic displays with this easily installed nozzle and enjoy a seamless performance at every show !

- ✓ Run-Stop Function with quick response time
- ✓ 24VDC Powered & IP68 Socket Connection
- ✓ DMX-RDM Speed Controlled
- ✓ Synchronorm Dependence Library available
- ✓ Run-Stop Function
- ✓ LIGHTxC (Optional)
- ✓ Power-saving electrical valve technology

DMX →  
← RDM



# SWITCH Musical Fountain Nozzle

With our new system, no additional control card is needed. The solenoid control circuit has been combined with the lighting unit. There is a lighting range from 4.5W to 56W.



HEIGHT	I / min	Bar	I / min	Bar
2.00 :	58	0,89	156	0,44
4.00 :	82	1,84	204	0,84
6.00 :	105	3,82	244	1,24

## Schematic :

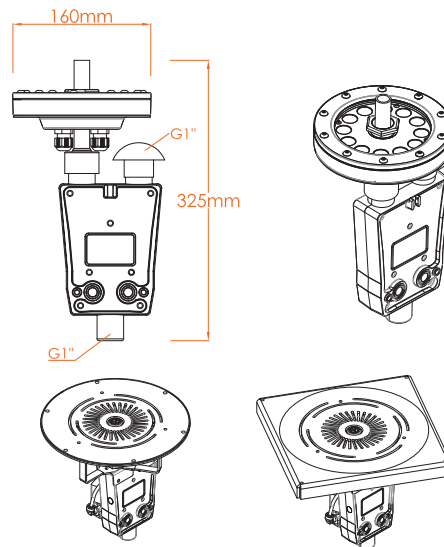

**i** More detail for DryDECK options please see page 40&41

## COMPATIBLE ELEMENTS AND ACCESSORIES

### PRODUCT GROUP SEE

**Nozzles :** Accessory nozzles

**Connection :** Connection accessories

**Controlling :** Control accessories

**Holder and Stand :** Holder and Stand Accs.

**Lighting :** Lighting Series

## TECHNICAL DETAILS

**MODEL :** SWITCH

**DIMENSION (LxWxH) :** 160x200x350 mm

**MATERIAL :** Stainless Steel

**WEIGHT :** 3.5 kg

**POWER & DMX :** Combo Cable

**MAX INLET :** 1" NPT

**PRODUCT NO :** 1041

