

ROBO Dancing Fountain Nozzle

The Art of Water Dance

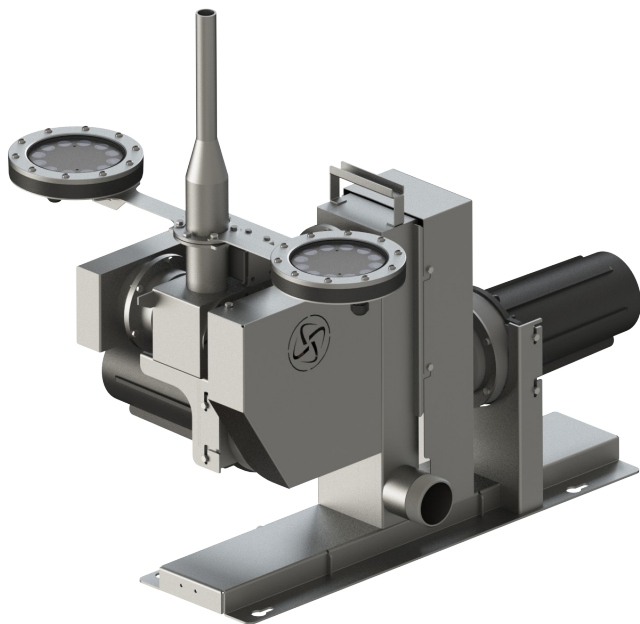

Enhance your animated fountain with our moving nozzles, designed to bring water to life! These advanced nozzles create dynamic, choreographed water patterns that dance and swirl, captivating audiences with their fluid motion. Ideal to catch the rhythms of music for animated fountains projects. With easy integration and reliable performance, they are the perfect addition to any animated fountain, transforming your water feature into an incredible visual attraction.



- ✓ Robust Stainless Steel Body
- ✓ 24VDC Powered & DMX-RDM Controlled
- ✓ IP68 Socket One Cable Connection
- ✓ Synchronorm Dependence Library available
- ✓ Different Nozzle Types With Flange Connection
- ✓ 180° Moving Angle on Each Axis
- ✓ IMU Sensor Integrated for Auto Calibration
- ✓ LIGHT x2 (Optional)
- ✓ Park Position and Zero Position Commands
- ✓ Servo Drive Control on 2-axis

ROBO Dancing Fountain Nozzle



Ø 17



Ø 20



Ø 23

NOZZLE TYPE

HEIGHT (M)	Ø 17	Ø 20	Ø 23
2.00 :	88 0.25	115 0.28	124 0.30
3.00 :	109 0.32	141 0.40	160 0.47
5.00 :	141 0.68	200 0.57	240 0.76
7.50 :	175 0.91	256 0.84	300 1.12
10.00 :	200 1.24	294 1.28	350 1.55
12.50 :	226 1.55	335 1.57	420 1.82
15.00 :		360 1.91	443 2.30
20.00 :		420 2.62	550 2.90

TECHNICAL DETAILS

MODEL :	ROBO
DIMENSION (LxMxH) :	600x727x730 mm
MATERIAL :	Stainless Steel
WEIGHT :	18 kg
POWER & DMX :	Combo Cable
WATER INLET :	2" NPT
NOZZLE OUTPUT :	1 ½"
MAX PRESSURE :	3.3 Bar
CURRENT :	2 A
POWER :	48 W
VOLTAGE :	24 VDC
PRODUCT NO :	1000

ROBO delivers an exceptional Water Dance Show with its advanced motion capabilities, moving 180 degrees on both axes. Powered by servo motors and controlled by a highly accurate 9-dof IMU sensor, it ensures smooth and perfect mechanical movements. IMU technology, used in aircraft and drones, provides precise speed and direction data, allowing exact nozzle positioning through dead reckoning.

ROBO's Motion Control System and optional lighting unit operate independently, but power and data signals are combined for efficient performance. This integrated Power & Data cable system is a key advantage over competitors. All connections utilize AquaTronic's waterproof sockets with double O-ring seals, ensuring faultless operation. This innovative approach provides both reliability and high performance. AquaROBO is designed to withstand extreme conditions, making it versatile for various environments. Its sophisticated technology and robust construction make AquaROBO a leader in water dance shows.

COMPATIBLE ELEMENTS AND ACCESSORIES

PRODUCT GROUP	SEE
Nozzles :	Accessory nozzles
Connection :	Connection accessories
Controlling :	Control accessories
Holder and Stand :	Holder and Stand Accs.
Lighting :	Lighting Series

ROBO Dancing Fountain Nozzle

The Art of Water Dance



IMU application, which is also used in aircraft, drones, and even guided missiles, has a high accuracy rate. With its full name, an Inertial Measurement Unit (IMU) uses accelerometers and gyroscopes to get information about speed and direction. This information is sent to the control card, and the processor on the card determines the location of the nozzle using the dead reckoning method. Thanks to the inventor of this system, we know the exact position of our nozzle during each step.

Schematic :

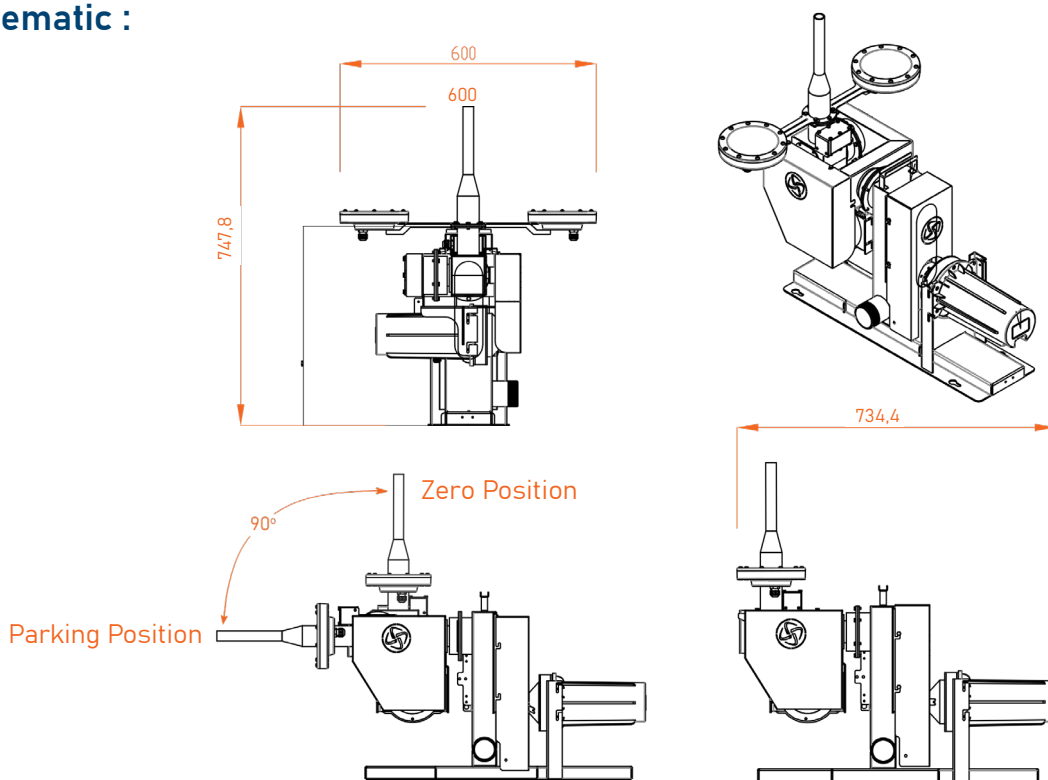

ROBO Dancing Fountain Nozzle



ROBO Motion Control System and optional lighting unit are separated. However, Power and Data signals are combined together. This combo (Power & Data) cable structure is one of our main superiorities compared to companies in the same branch. All connections are made by TNC-designed waterproof sockets. The double O-ringed socket connections eliminate faults.

Electrical Connection Schematic :

